

## ROTANODE

E7252X

E7252FX

E7252GX



### Rotating Anode X-Ray Tube Housing Assembly

- ◆ High speed rotating anode X-ray tube housing assembly for high energy radiographic and cine-fluoroscopic operations.
- ◆ The heavy anode is constructed with specially processed rhenium-tungsten faced molybdenum target which is 74 mm diameter and has an improved coating to increase thermal emissivity.
- ◆ These tubes have foci 1.2 mm and 0.6 mm, and are available for a maximum tube voltage 150 kV with Three-phase generator.
- ◆ Accommodated with IEC60526 type high-voltage cable receptacles.



### General Data

**IEC Classification** ..... **Class I**

#### Electrical:

Circuit (Center-grounded) ..... Three-phase full-wave rectified

Nominal Tube Voltage:

Radiographic ..... 40 ~ 150 kV Max.

Fluoroscopic ..... 40 ~ 125 kV Max.

Nominal Focal Spot Value:

Large Focus ..... 1.2 mm

Small Focus ..... 0.6 mm

Nominal Anode Input Energy (at 0.1s):

Large Focus ..... 75 kW

Small Focus ..... 27 kW

★The information contained herein is presented only as a guide for the applications of our products.  
 No Responsibility is assumed by TOSHIBA ELECTRON TUBES & DEVICES CO.,LTD.(TETD) for any infringements of patents or other rights of the third parties which may result from its use. No license is granted by implication or otherwise under any patent or patent rights of TETD or others.  
 ★The information contained herein may be changed without prior notice. It is therefore advisable to contact TETD before proceeding with the design of equipment incorporating this product.  
 ★For further particulars apply to TETD.

Motor Ratings:

Stator: XS-AL

Duty		Starting		Running	
Power source	(Hz)	180 <sup>2)</sup>	60	180 <sup>2)</sup>	60
Input power	(W)	1100	910	83	83
Voltage <sup>4)</sup>	(V)	220	130	60	40
Current	(A)	5.7	7.8	1.6	2.3
Min. Speed up <sup>1) 5)</sup>	(s)	1.2	0.8	-	-
Capacitor	( $\mu$ F)	6	44	6	44
Min. Braking <sup>2)</sup>	(s)	3 / 90 V (DC)			

Stator impedance:

Common-Main Winding ..... 9.4  $\Omega$   
 Common-Auxiliary Winding..... 28.3  $\Omega$

Stator: XS-R

Duty		Starting		Running	
Power source	(Hz)	180 <sup>3)</sup>	50/60	180 <sup>3)</sup>	50/60
Input power	(W)	2300	1450	300	80
Voltage <sup>4)</sup>	(V)	460	240	130	58
Current	(A)	5.4	6.5	2.0	1.5
Min. Speed up <sup>1) 5)</sup>	(s)	1.0	0.6	-	-
Capacitor	( $\mu$ F)	3	24	3	24
Min. Braking <sup>2)</sup>	(s)	1.5 / 90 V (DC) <sup>3)</sup>			

- Note 1) The speed up time from normal speed of 3000 min<sup>-1</sup> (3600 min<sup>-1</sup>) to high speed of 10800 min<sup>-1</sup> is 2/3 times of the specified speed up time from 0 to high speed, which is described on motor rating table.  
 2) To be applied for high speed rotation.  
 3) To be obtained with AID starter Model 60/180.  
 4) The every applied voltage must be never exceeded 110% of the above specification.  
 5) The speed-up time is allowed up to 110% of the above specification.

Stator impedance:

Common-Main Winding ..... 27.5  $\Omega$   
 Common-Auxiliary Winding..... 58.0  $\Omega$

Anode Speed:

50 Hz ..... 2700 min<sup>-1</sup> Min.  
 60 Hz ..... 3200 min<sup>-1</sup> Min.  
 180 Hz ..... 9700 min<sup>-1</sup> Min.

Resistance between Housing and Low Voltage Terminals ..... 2 M $\Omega$  Min.

Normal operating range of the housing temperature ..... 16 ~ 75 °C

**Mechanical:**

Dimensions: .....	See dimensional outline
Overall Length .....	476 mm
Maximum Diameter .....	152.4 mm
Target:	
Angle .....	12 degrees
Diameter .....	74 mm
Construction .....	Rhenium-Tungsten faced Molybdenum
Permanent Filtration .....	0.9 mm Al / 75 kV IEC60522 / 2003
Radiation Protection (To meet the requirements of IEC 60601-1-3):	
Leakage Technique Factor .....	150 kV 3.4 mA
X-ray Coverage .....	354 × 354 mm at SID 835 mm
Weight (Approx.) .....	18 kg
High Tension Terminals .....	To meet the requirements of IEC 60526
Cooling Method .....	Natural or forced air
Tube Housing Model Number:	
E7252X .....	XH-106V
E7252FX .....	XH-180
E7252GX .....	XH-181

## **Absolute Maximum and Minimum Ratings**

**(At any time, these values must not be exceeded.)**

**Maximum Tube Voltage:**

Radiographic .....	150 kV
Fluoroscopic .....	125 kV

Maximum Voltage to Ground ..... 78 kV

Minimum Tube Voltage ..... 50 kV

**Maximum Tube Current:**

Large Focus .....	1000 mA
Small Focus .....	400 mA

**Maximum Filament Current:**

Large Focus .....	5.5 A
Small Focus .....	5.2 A

**Filament Voltage:**

Large Focus (At max. filament current 5.5 A) .....	12.7 ~ 17.1 V
Small Focus (At max. filament current 5.2 A) .....	7.0 ~ 9.4 V

Filament Frequency Limits ..... 0 ~ 25 kHz

Average Input Power ..... 142 W (200 HU/s)

(Fluoroscopic, repeated radiographic or mixed exposure)

**Thermal Characteristics:**

Anode Heat Content ..... 210 kJ (300 kHU)

Maximum Anode Heat Dissipation Rate ..... 475 W (667 HU/s)

X-ray Tube Assembly Heat Content ..... 900 kJ (1250 kHU)

**Maximum Housing Heat Dissipation Rate:**

Without Air-circulator ..... 200 W (16 kHU/min)

## Environmental Limits

### Operating Limits:

Temperature .....	10 ~ 40 °C
Humidity .....	30 ~ 85 %
	(No condensation)
Atmospheric Pressure .....	70 ~ 106 kPa

### Shipping and Storage Limits:

Temperature .....	-20 ~ 70 °C
Humidity .....	20 ~ 90 %
	(No condensation)
Atmospheric Pressure .....	50 ~ 106 kPa

## The information about EMC conformity (IEC60601-1-2 Ed2/2001)

As the result of reviewing the test requirements in the following Tables, an X-ray tube assembly as a component of X-ray system or apparatus does not fall within the scope of the EMC directive of IEC60601-1-2: 2001. Therefore, X-ray system manufacturer shall conduct the required test and evaluate EMC.

**CAUTION:** The diagnostic X-ray system can only allow to use the designated cables and components. If the different cables or components are used, they may deteriorate the performance of electromagnetic emissions and immunity.

The following tables are the copies of statements in IEC60601-1-2: 2001

**Table 1 – Guidance and manufacturer’s declaration – electromagnetic emissions – for all EQUIPMENT and SYSTEMS (see 6.8.3.201 a) 3))**

<b>Guidance and manufacturer’s declaration – electromagnetic emissions</b>		
The [EQUIPMENT or SYSTEM] is intended for use in the electromagnetic environment specified below. The customer or the user of the [EQUIPMENT or SYSTEM] should assure that it is used in such an environment.		
<b>Emission test</b>	<b>Compliance</b>	<b>Electromagnetic environment - guidance</b>
RF emissions CISPR 11	Group 1	The [EQUIPMENT or SYSTEM] uses RF energy only for its internal function. Therefore, its RF emissions are very low and are not likely to cause any interference in nearby electronic equipment.
RF emissions CISPR 11	Group 2	The [EQUIPMENT or SYSTEM] must emit electromagnetic energy in order to perform its intended function. Nearby electronic equipment may be affected.
RF emissions CISPR 11	Class [A or B]	
Harmonic emissions IEC 61000-3-2	Class [A, B, C, D, or Not applicable]]	
Voltage fluctuations/ flicker emissions IEC 61000-3-3	[Complies or Not applicable]	
	[See 6.8.3.2001 a) 3) and Figure 201]	The [EQUIPMENT or SYSTEM] is suitable for use in all establishments, including domestic establishments and those directly connected to the public low-voltage power supply network that supplies buildings used for domestic purposes.
	[See 3.8.3.201 a) 3) and Figure 201]	The [EQUIPMENT or SYSTEM] is suitable for use in all establishments other than domestic and these directly connected to the public low-voltage power supply network that supplies buildings used for domestic purposes.
RF emissions CISPR 14-1	Complies	The [EQUIPMENT] is not suitable for interconnection with other equipment.
RF emissions CISPR 15	Complies	The [EQUIPMENT] is not suitable for interconnection with other equipment.

**Table 2 – Guidance and manufacturer’s declaration – electromagnetic immunity –  
for all EQUIPMENT and SYSTEMS (see 6.8.3.201 a) 6))**

<b>Guidance and manufacturer’s declaration – electromagnetic immunity</b>			
The [EQUIPMENT or SYSTEM] is intended for use in the electromagnetic environment specified below. The customer or the user of the [EQUIPMENT or SYSTEM] should assure that it is used in such an environment.			
<b>Immunity test</b>	<b>IEC 60601 test level</b>	<b>Compliance level</b>	<b>Electromagnetic environment – guidance</b>
Electrostatic discharge (ESD) IEC 61000-4-2	±6 kV contact ±8 kV air		Floors should be wood, concrete or ceramic tile. If floors are covered with synthetic material, the relative humidity should be at least 30 %.
Electrical fast transient/burst IEC 61000-4-4	±2 kV for power supply lines ±1 kV for input/output lines		Mains power quality should be that of a typical commercial or hospital environment.
Surge IEC 61000-4-5	±1 kV differential mode ±2 kV common mode		Mains power quality should be that of a typical commercial or hospital environment.
Voltage dips, short interruptions and voltage variations on power supply input lines. IEC 61000-4-11	<5 % $U_T$ (>95 % dip in $U_T$ ) for 0.5 cycle  40 % $U_T$ (60 % dip in $U_T$ ) for 5 cycle  70 % $U_T$ (30 % dip in $U_T$ ) for 25 cycle  <5 % $U_T$ (>95 % dip in $U_T$ ) for 5 sec		Mains power quality should be that of a typical commercial or hospital environment. If that user of the [EQUIPMENT or SYSTEM] requires continued operation during power mains interruptions, it is recommended that the [EQUIPMENT or SYSTEM] be powered from an uninterruptible power supply or a battery.
Power frequency (50/60 Hz) magnetic field IEC 61000-4-8	3 A/m		Power frequency magnetic fields should be at levels characteristic of a typical location in a typical commercial or hospital environment.
NOTE $U_T$ is the a.c. mains voltage prior to application of the test level.			

**Table 3 – Guidance and manufacturer’s declaration – electromagnetic immunity – for LIFE-SUPPORTING EQUIPMENT and SYSTEM (see 6.8.3.201 b))**

<b>Guidance and manufacturer’s declaration - electromagnetic immunity -</b>			
The [EQUIPMENT or SYSTEM] is intended for use in the electromagnetic environment specified below. The customer or the user of the [EQUIPMENT or SYSTEM] should assure that it is used such an environment.			
<b>Immunity test</b>	<b>IEC60601 test level</b>	<b>Compliance level</b>	<b>Electromagnetic environment - guidance</b>
Conducted RF IEC61000-4-6	3 Vrms 150 kHz to 80 MHz outside ISM bands <sup>a</sup>	[V <sub>1</sub> ] V	Portable and mobile RF communications equipment should be used no closer to any part of the [EQUIPMENT or SYSTEM], including cables, than the recommended separation distance calculated from the equation applicable to the frequency of the transmitter.  <b>Recommended separation distance</b>  $d = \left[ \frac{3.5}{V_1} \right] \sqrt{P}$  $d = \left[ \frac{12}{V_2} \right] \sqrt{P}$
	10 Vrms 150 kHz to 80 MHz in ISM bands <sup>a</sup>	[V <sub>2</sub> ] V	
Radiated RF IEC61000-4-3	10 V/m 80 MHz to 2.5GHz	[E <sub>1</sub> ] V/m	$d = \left[ \frac{12}{E_1} \right] \sqrt{P}$ 80 MHz to 800 MHz  $d = \left[ \frac{23}{E_1} \right] \sqrt{P}$ 800 MHz to 2.5 GHz  Where <i>P</i> is the maximum output power rating of the transmitter in watts (W) according to the transmitter manufacturer and <i>d</i> is the recommended separation distance in meters (m). <sup>b</sup>  Field strengths from fixed RF transmitters, as determined by an electromagnetic site survey, <sup>c</sup> should be less than the compliance level in each frequency range <sup>d</sup> .  Interference may occur in the vicinity of equipment marked with the following symbol:  

Continued to the next page.

Note: 1 At 80 MHz and 800 MHz, the higher frequency range applies.

2 These guidelines may not apply in all situations. Electromagnetic propagation is affected by absorption and reflection from structures, object and people.

<sup>a</sup> The ISM (industrial, scientific and medical) bands between 150kHz and 80MHz are 6,765MHz to 6,795MHz; 13,553MHz to 13,567MHz; 26,957MHz to 27,283MHz; and 40.66MHz to 40.70MHz.

<sup>b</sup> The compliance levels in the ISM frequency bands between 150kHz and 80MHz and in the frequency range 80MHz to 2.5GHz are intended to decrease the likelihood that mobile/portable communications equipment could cause interference if it is inadvertently brought into patient areas. For this reason, an additional factor of 10/3 is used in calculating the recommended separation distance for transmitters in these frequency ranges.

<sup>c</sup> Field strengths from fixed transmitters, such as base stations for radio (cellular/cordless) telephones and land mobile radios, amateur radio, AM and FM radio broadcast and TV broadcast cannot be predicted theoretically with accuracy. To assess the electromagnetic environment due to fixed RF transmitters, an electromagnetic site survey should be considered. If the measured field strength in the location in which the [EQUIPMENT or SYSTEM] is used exceeds the applicable RF compliance level above, the [EQUIPMENT or SYSTEM] should be observed to verify normal operation. If abnormal performance is observed, additional measures may be necessary, such as reorienting or relocating the [EQUIPMENT or SYSTEM].

<sup>d</sup> Over the frequency range 150kHz to 80MHz, field strengths should be less [ $V_1$ ] v/m.

**Table 4 – Guidance and manufacturer’s declaration – electromagnetic immunity – for EQUIPMENT and SYSTEM that are not LIFE-SUPPORTING (see 6.8.3.201 b))**

<b>Guidance and manufacturer’s declaration - electromagnetic immunity -</b>			
The [EQUIPMENT or SYSTEM] is intended for use in the electromagnetic environment specified below. The customer or the user of the [EQUIPMENT or SYSTEM] should assure that it is used in such an environment.			
<b>Immunity test</b>	<b>IEC60601 test level</b>	<b>Compliance level</b>	<b>Electromagnetic environment - guidance</b>
Conducted RF IEC61000-4-6	3 Vrms 150 kHz to 80 MHz	[V1] V	Portable and mobile RF communications equipment should be used no closer to any part of the [EQUIPMENT or SYSTEM], including cables, than the recommended separation distance calculated from the equation applicable to the frequency of the transmitter.  <b>Recommended separation distance</b> $d = \left[ \frac{3.5}{V1} \right] \sqrt{P}$
Radiated RF IEC61000-4-3	3 V/m 80 MHz to 2.5GHz	[E1] V/m	$d = \left[ \frac{3.5}{E1} \right] \sqrt{P}$ 80 MHz to 800 MHz  $d = \left[ \frac{7}{E1} \right] \sqrt{P}$ 800 MHz to 2.5 GHz  Where $P$ is the maximum output power rating of the transmitter in watts (W) according to the transmitter manufacturer and $d$ is the recommended separation distance in meters (m).  Field strengths from fixed RF transmitters, as determined by an electromagnetic site survey, <sup>a</sup> should be less than the compliance level in each frequency range <sup>b</sup> .  Interference may occur in the vicinity of equipment marked with the following symbol:  
<p>Note: 1 At 80MHz and 800MHz, the higher frequency range applies.                  2 These guidelines may not apply in all situations. Electromagnetic propagation is affected by absorption and reflection from structures, object and people.</p>			
<p><sup>a</sup> Field strengths from fixed transmitters, such as base stations for radio (cellular/cordless) telephones and land mobile radios, amateur radio, AM and FM radio broadcast and TV broadcast cannot be predicted theoretically with accuracy. To assess the electromagnetic environment due to fixed RF transmitters, an electromagnetic site survey should be considered. If the measured field strength in the location in which the [EQUIPMENT or SYSTEM] is used exceeds the applicable RF compliance level above, the [EQUIPMENT or SYSTEM] should be observed to verify normal operation. If abnormal performance is observed, additional measures may be necessary, such as reorienting or relocating the [EQUIPMENT or SYSTEM].</p>			
<p><sup>b</sup> Over the frequency range 150kHz to 80MHz, field strengths should be less [V<sub>1</sub>] v/m.</p>			

## Warning

### Warning to Interface with X-ray Generator

#### 1. Housing Rupture

Never input over-rated power to x-ray tube assembly.

If the input power is extremely higher than specification, it may cause the over temperature of anode, insert tube glass shatter and ultimately the following serious problems due to generating over-pressure by oil vaporization inside housing assembly.

In such a critical condition, the safety thermal switch can not protect x-ray tube even if it works.

- \* Housing sealing parts rupture
- \* Human injury including burns due to hot oil escape
- \* Fire accident due to flaming anode target

We strongly request that the x-ray generator should have a protective function which manages input power to x-ray tube assembly.

## Cautions

### Caution to Interface with X-ray Generator

1. Over Rating

X-ray tube assembly can be broken with applying just one over rated shot.  
Please read the technical data sheets carefully and follow the instructions.

2. Permanent Filtration

The total filtration and the distance between x-ray focal spot and human body are regulated legally.  
They should be complied with the regulation.

3. Safety Thermal Switch

X-ray tube assembly has safety thermal switch to prohibit further input power when the tube housing reaches to the temperature of switch-open.

The switch should be hooked up with the x-ray generator which control output power to x-ray tube assembly.

The switch is not recommended connecting stator coil in series circuit.

Even if the switch works, never turn the system power off and the cooling unit should be activated.

4. Unexpected Malfunction

X-ray tube assembly may have the risk to be unexpectedly malfunctioning due to life termination or failure. If the serious problems caused by the above risk is expected, we recommend to have a contingency plan to avoid such a case.

5. New Application

If you use the product with new application not to be mentioned in this specification or with different type of x-ray generator, please contact to us for confirming its availability.

## Caution for Installation, Adjustment and Maintenance

### 1. Qualified Persons

Only qualified persons who have technical training and professional knowledge can handle x-ray tube assembly.

### 2. Fragile Glass

X-ray tube is assembled with glass, therefore, it can be broken with the mechanical vibration or pulsed shock over  $19.6\text{m/s}^2$  (2G).

Careful handling is required to treat or transport.

### 3. Ground Terminal

X-ray tube assembly has ground terminal. Ground cable should be connected.

### 4. High Voltage

All x-ray tubes operate at voltages high enough to kill through electrical shock. Never touch the high voltage delivered plugs or terminals.

When direct access to such parts is required, the primary circuit should be disabled and high voltage capacitors/cables discharged.

### 5. High Voltage Plug

High voltage plug should be cleaned up and free from any physical damages. Silicon compound application is required for high voltage stability.

### 6. Operation Atmosphere

X-ray tube assembly is not allowed to use in the atmosphere of flammable or corrosive gas.

### 7. Protective Cover

X-ray tube assembly is not allowed to use without the protective cover attached.

### 8. Handling

Appropriate jig or tools are required for tube installation to avoid physical damages.

### 9. Returning Tube

X-ray tube assembly should be repackaged with the original material when it is returned back for quality examination in our factory.

Be careful to put the tube upside cathode. If the packaging is not proper, the tube may not be correctly examined.

### Caution in Operation

1. X-Ray Radiation

X-ray tube assembly should have the beam limiting equipment mounted on the x-ray port to protect unnecessary radiation.

2. Dielectric Oil

X-ray tube assembly has dielectric oil contained for high voltage stability. As it is poisonous for human health, if it is exposed to the non-restricted area, it should be disposed as following to the local regulation.

3. Operation Atmosphere

X-ray tube assembly is not allowed to use in the atmosphere of flammable or corrosive gas.

4. Lead Disposition

X-ray tube housing is lined with lead to protect unnecessary radiation. As the lead powder or vapor is harmful for human health, it should be disposed as following to the local regulation or returned back to us with your cost of transportation. We dispose it in our facility with free of charge.

5. X-ray tube housing temperature

Do not touch on X-ray tube housing surface just after operation due to high temperature.  
Stay X-ray tube to be cooled.

6. Any Malfunction

Please contact to your system service person immediately, if any malfunction is noticed.

## Caution Label

- (a) This label is a caution label to notify the user of the following point.  
"Housing end cap is used to protect the electric shock and x-ray leakage."

Attachment position : X-ray tube assembly housing end cap



## Maximum Rating Charts

(Absolute Maximum Rating Charts)

Conditions : Tube Voltage Three-Phase

Stator Power Frequency 180Hz

Focal Spot : 1.2 mm

Focal Spot : 0.6 mm

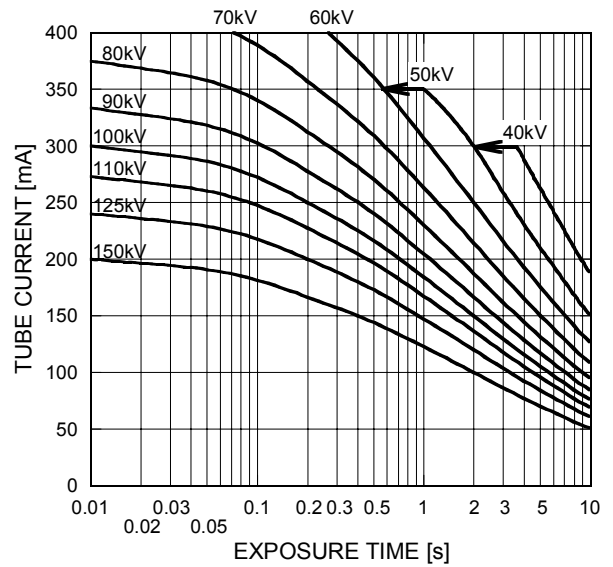
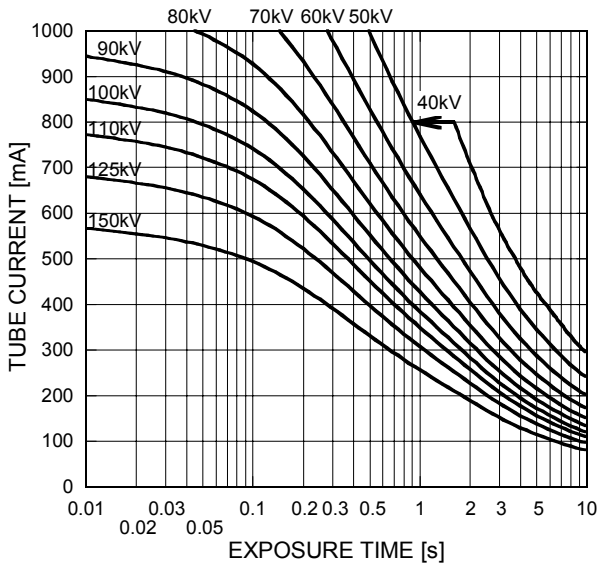

Conditions : Tube Voltage Three-Phase

Stator Power Frequency 60Hz

Focal Spot : 1.2 mm

Focal Spot : 0.6 mm

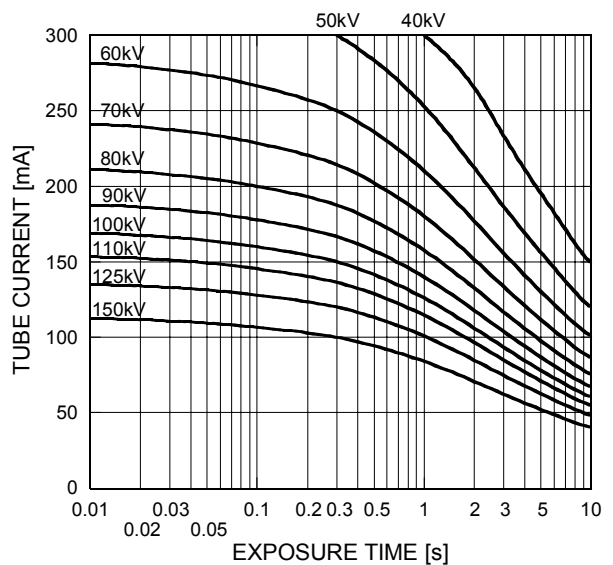
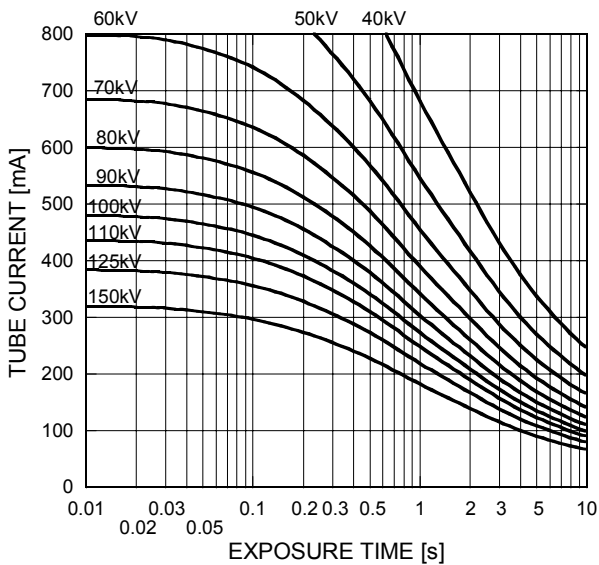

## Emission & Filament Characteristics

Three-Phase

Focal Spot : 1.2 mm

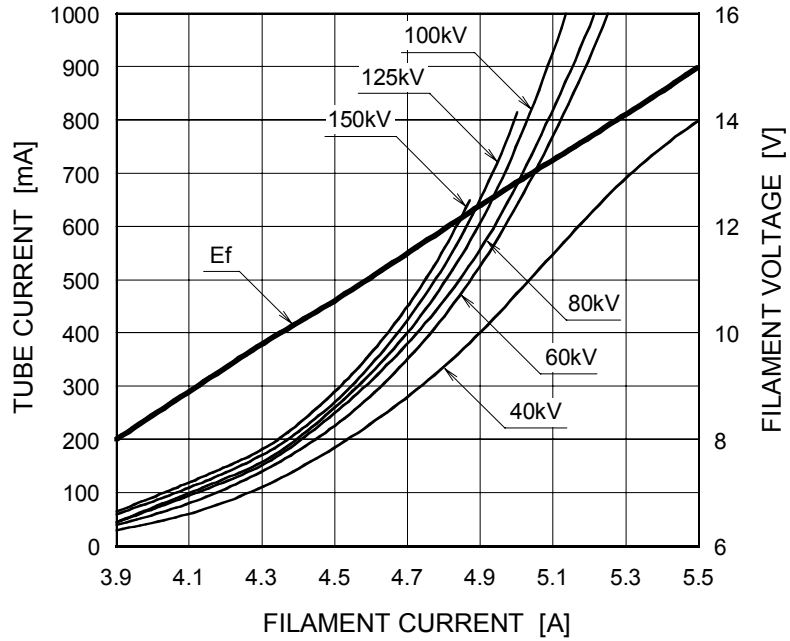

Focal Spot : 0.6 mm

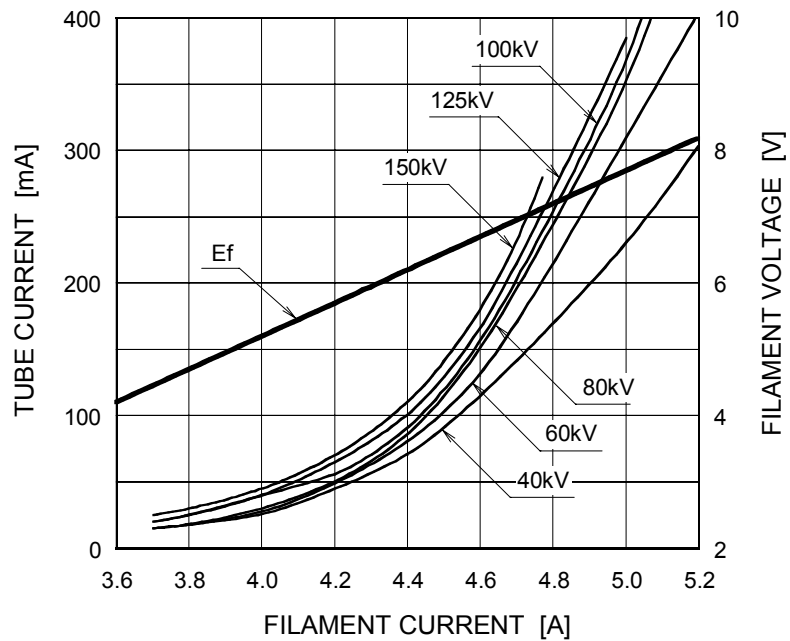

## Thermal Characteristics

Housing Thermal Characteristics

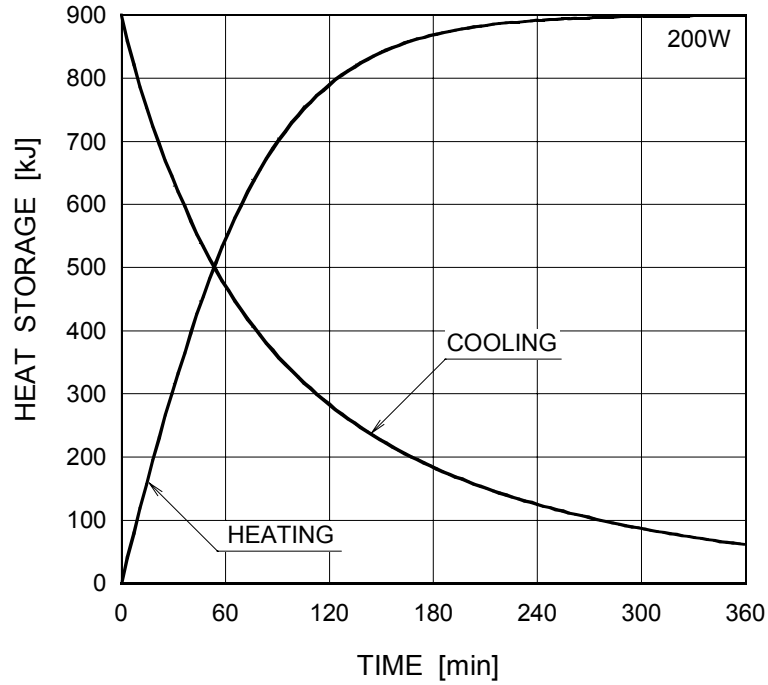

Anode Thermal Characteristics

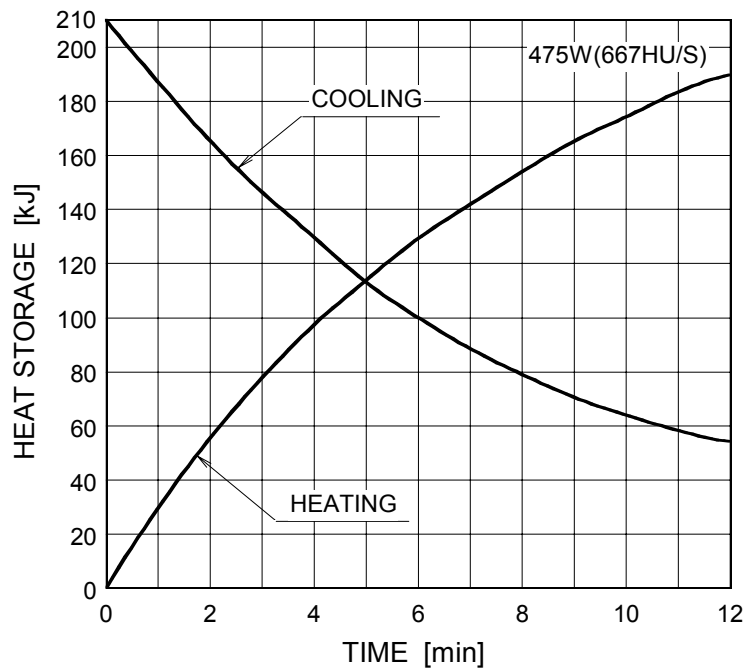

The heating curves are showing examples of average input power to the anode in operation.

### Dimensional Outline of E7252X

Unit mm

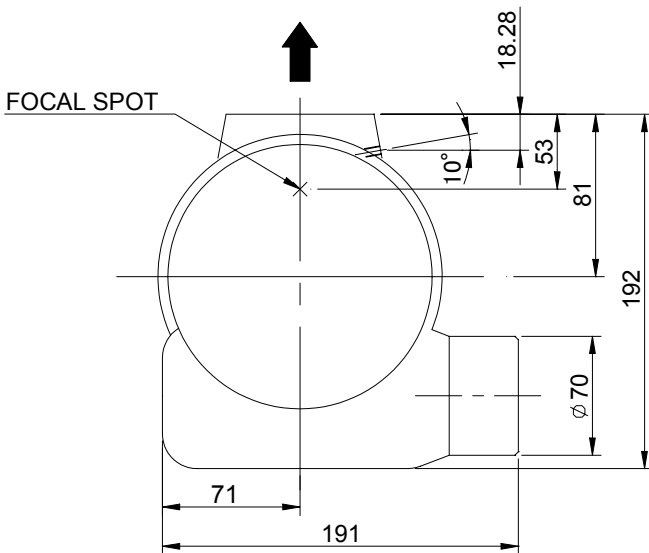
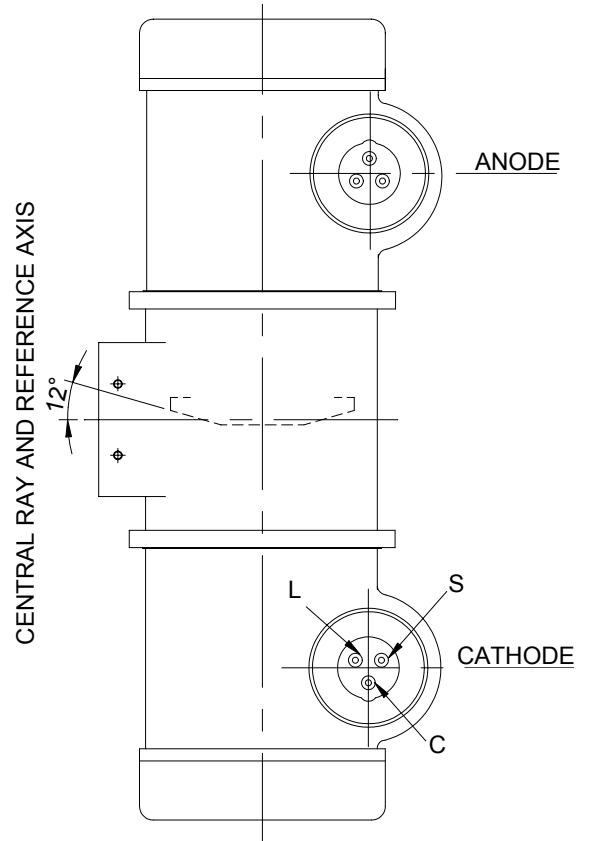
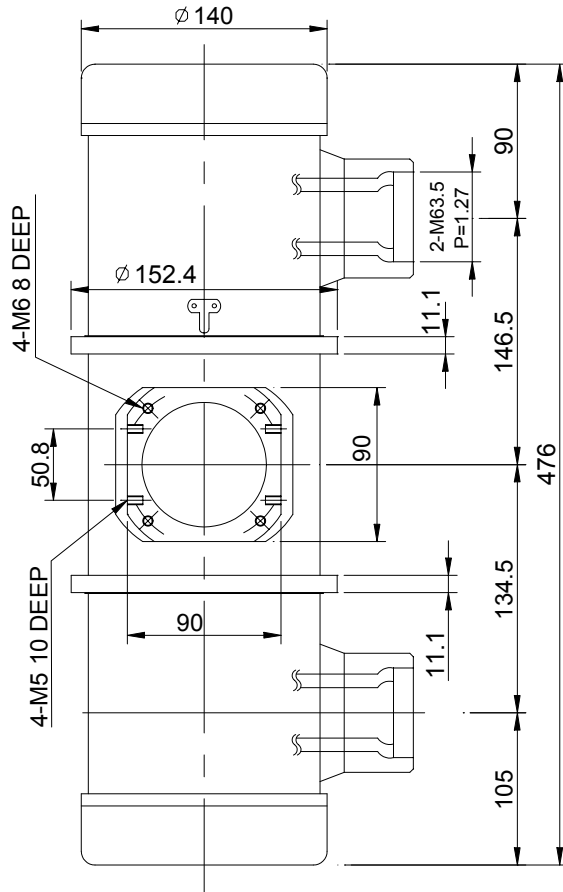

#### TERMINAL CONNECTIONS

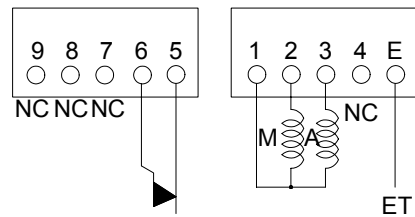

TEMPERATURE RELAY  
(NORMALLY CLOSED)

Note) Do not connect terminal No.1 and No.5 or 6  
in series circuit.

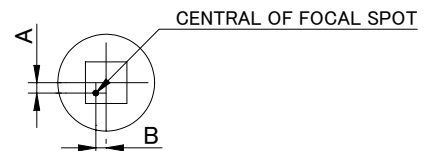

A: ±1.5mm, B: ±1.5mm

- C : COMMON
- L : LARGE FOCUS
- S : SMALL FOCUS
- M : MAIN WINDING OF THE STATOR
- A : AUX. WINDING OF THE STATOR

- NC : NON-CONNECTION
- ET : EARTH TERMINAL
- ▲ : CENTRAL X-RAY
- ANODE & CATHODE TERMINAL : IEC 60526 TYPE

## Dimensional Outline of E7252FX

Unit mm

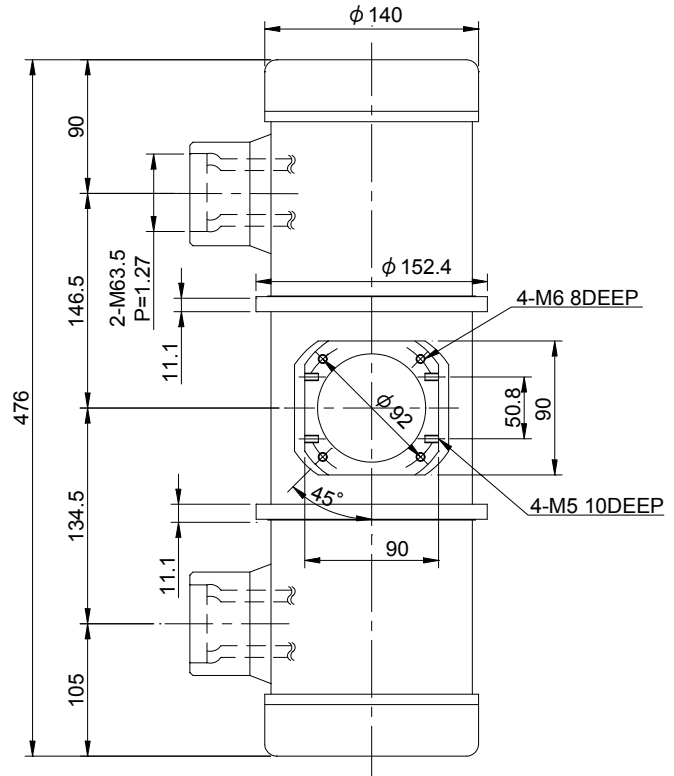
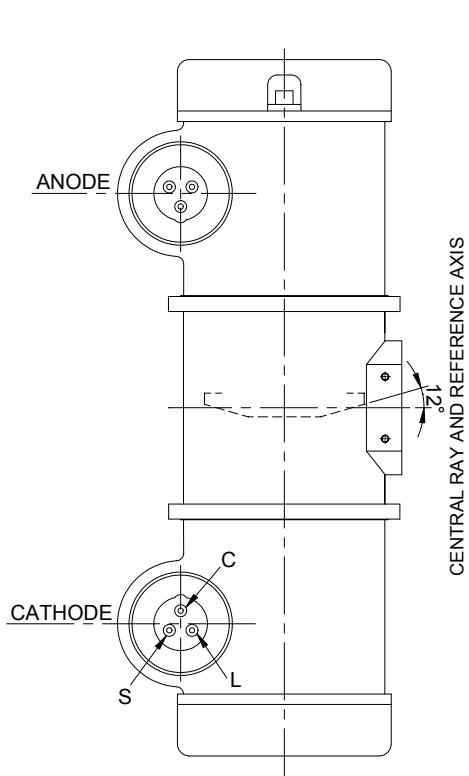

### TERMINAL CONNECTIONS

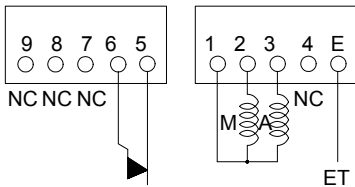

TEMPERATURE RELAY  
(NORMALLY CLOSED)

Note) Do not connect terminal No.1 and No.5 or 6 in series circuit.

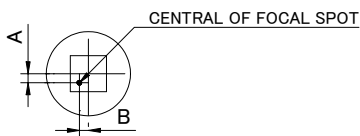

A:  $\pm 1.5$ mm, B:  $\pm 1.5$ mm

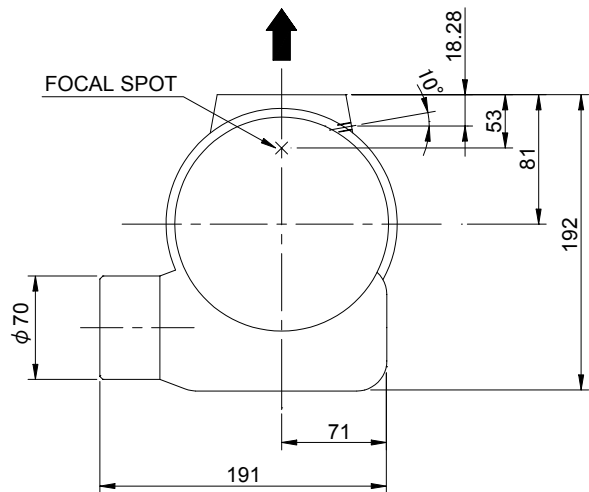

- C : COMMON
- L : LARGE FOCUS
- S : SMALL FOCUS
- M : MAIN WINDING OF THE STATOR
- A : AUX. WINDING OF THE STATOR

- NC : NON-CONNECTION
- ET : EARTH TERMINAL
- ▲ : CENTRAL X-RAY
- ANODE & CATHODE TERMINAL : IEC60526 TYPE



## OVERSEAS SUBSIDIARIES AND AFFILIATES

### EU REPRESENTATIVE

#### •TOSHIBA ELECTRONICS EUROPE

RIVERSIDE WAY, CAMBERLEY, SURREY. GU15 3YA U.K.  
PHONE (0) 1276 694600 FAX (0) 1276 694800

**For Sales & Technical Services, please contact the following representative:**

#### •TOSHIBA ELECTRONICS EUROPE

RIVERSIDE WAY, CAMBERLEY, SURREY. GU15 3YA U.K.  
PHONE (0) 1276 694600 FAX (0) 1276 694800

#### •TOSHIBA AMERICA ELECTRONIC COMPONENTS, INC.

2150 EAST LAKE COOK ROAD, SUITE 310  
BUFFALO GROVE, ILLINOIS 60089 USA  
PHONE (847) 945-1500 FAX (847) 945-1044

#### •TOSHIBA ELECTRON DEVICES & MATERIALS TRADING (SHANGHAI) CO., LTD. (TEMS)

No.689, GUANG DONG RD, SHANGHAI, 200001, CHINA  
RM607, HAITONG SECURITIES TOWER  
PHONE (21) 6341-0055 FAX (21) 6341-0990

---

### TOSHIBA ELECTRON TUBES & DEVICES CO., LTD.

Sales & Marketing Department

1385 SHIMOISHIGAMI, OTAWARA-SHI, TOCHIGI-KEN, 324-8550, JAPAN

PHONE : +81-287-26-6666 FAX : +81-287-26-6060

<http://www.toshiba-tetd.co.jp/>



Toshiba Electron Tubes & Devices Co., Ltd.  
meets the Environmental Management  
System Standard, ISO 14001



Toshiba Electron Tubes & Devices Co., Ltd. meets  
internationally recognized Standards for Quality  
Management System ISO 9001, ISO 13485